

Braille Block Detection for Autonomous Mobile Robot Navigation

Tomoaki Yoshida

Akihisa Ohya

Shin'ichi Yuta

Intelligent Robot Laboratory
University of Tsukuba
Tsukuba 305-8573, Japan
{yos,ohya,yuta}@roboken.esys.tsukuba.ac.jp

Abstract

A mobile robot can use the walls or the pillars to localize itself when it navigates in indoor environment. However, in open space or outdoor environment there are few easy detectable and stable object that the robot can use. In this paper, we propose a method for the detection of braille blocks, which are originally used for visually handicapped people, for autonomous mobile robot navigation. To recognize the braille block, a CCD camera and a laser fan beam projector are used as sensor to detect bumps on road surface. This paper also presents the experimental results of braille block following using the sensor system to detect the braille block position and orientation. This experiment shows effectiveness of the sensor system for the braille block recognition and implies the possibility of braille block based mobile robot navigation.

1 Introduction

Localization is an important function of autonomous mobile robot. In indoor environments, there are many objects which are easily observed such as walls, doors and pillars. These objects are also easily recognized by human, so environmental maps for mobile robots can be built easily by human. On the other hand, localization in outdoor environments is not easy. Some projects use the image processing technology for localization[2][3][5], but their systems are too complex and too large to implement into a small sized mobile robot.

There are many places where braille blocks are placed these days in urban areas in Japan and some other countries. The braille block is a safety equipment for visually handicapped people. Hence they can walk along the street using information of the braille blocks. In this study, we use the braille blocks to guide the autonomous mobile robot.

In this paper, we describe mobile robot navigation us-

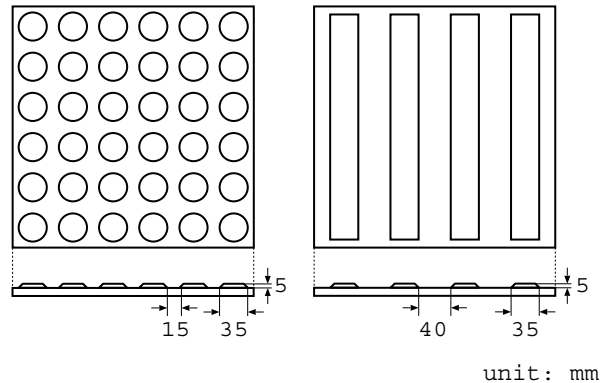

Figure 1: Two styles of braille block

left: dot style block
right: line style block

ing the braille blocks. At first, what the braille blocks are and how the mobile robot uses them for navigation are described. Then the mobile robot system including sensors and controllers we have developed are described. And finally, experimental result of the localization process using the braille blocks is discussed.

2 The braille block

There are two kinds of braille blocks, dot style block and line style block. Fig. 1 shows the shape of blocks having line style or dot style of convex parts which are 5mm high. The standard color of the block is yellow, but several variations are permitted.

When a visually handicapped people step on the blocks, using the sense of touch through their soles, they can know information about the street such as the direction they can move and the existence of junctions.

Fig.2 shows an example of the actual braille block ar-

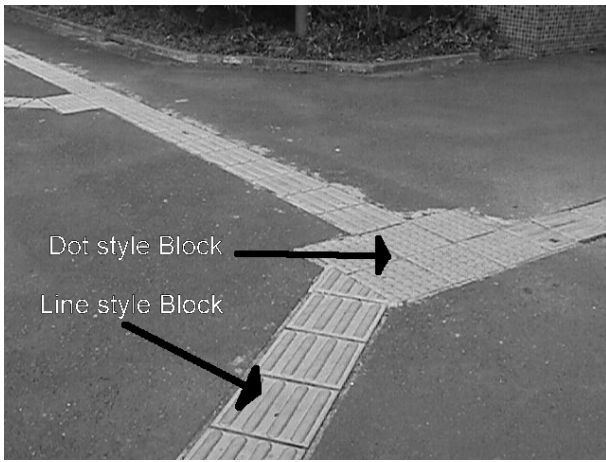

Figure 2: Example of braille blocks on pedestrian

rangement. Line style blocks are usually arranged in line and figures the position and direction of the path. At the corner of the path, dot style blocks are placed. Dot style blocks are placed also at the junction of the path and some interesting places such as bus stops or the entrances of buildings.

3 Utilization of braille blocks for mobile robots

In structured environments, wall following and line tracing are easy and effective method for mobile robot to track the pre-defined long path.

Using sequence of the line style blocks as pre-defined path, outdoor environment can be simplified. Basically the mobile robot follows the sequence of line style block. When a dot style block is found, using a map built in advance by human, the robot can decide the next action. Building the map is relatively easy because the path is already defined as sequence of line style blocks and the length of the path can be measured by counting the number of the blocks.

3.1 Detection of braille blocks

Braille blocks have two major special features which are used to distinguish them from normal road surface. One is its color, which normally is yellow. This feature is for weak eyesight people and help them to find it by its high contrast color. This feature can be used to detect the blocks with color camera[6]. However this is recommended feature by the guide line and not mandatory, so it is not always yellow

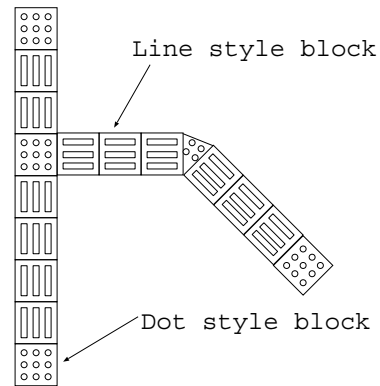

Figure 3: Example pattern of the braille block

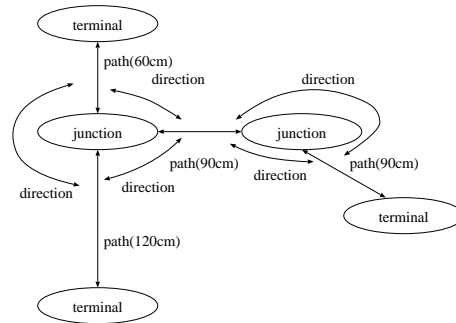

Figure 4: Corresponding environmental map to the block pattern shown in Fig.3

especially in sight aware place. Also with this feature, it is hard to distinguished the type of braille block.

The other feature is its physical shape. The height of its convex part is 5mm regardless of the type of the braille block, and the type of the block can be distinguished only by the shape of convex part. We use this feature for detecting the braille blocks with the laser fan beam projector and a camera. In this way, it should be possible to detect the existence of block and recognize the type and position and direction of the sequence of blocks.

3.2 Map of braille blocks

The mobile robot should have information about the braille block arrangement as an environmental map so that the robot can plan the path using the map. The map should contain the following information.

- Length of the sequence of the line style blocks
- The junction or the corner where the dot style blocks are placed and directions of the paths connected to the

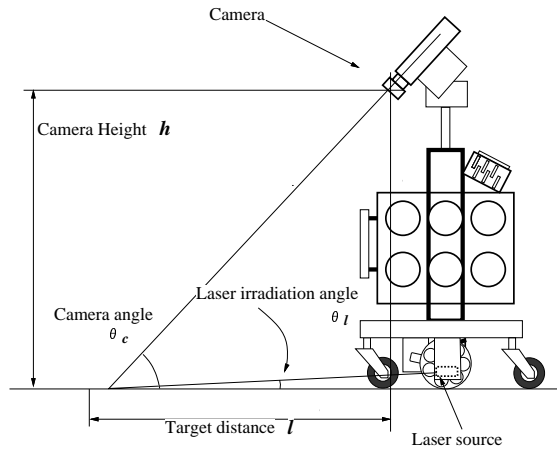

Figure 5: Configuration of the laser source and the camera

junction

- Terminal of the sequence of braille blocks

Fig.3 shows a example pattern of braille blocks, and the corresponding environmental map should contain the information shown in Fig.4.

The length of the path is used to predict that a dot style block could exist at the end of the path. With this prediction, the robot can slow down and carefully search for the dot style block if necessary.

3.3 Navigation with braille blocks

By giving the current and target position in the environmental map, the mobile robot can plan a path on the map and navigates itself to the target position . Navigation is done by tracing the sequence of line style blocks and choosing the proper path at a junction according to the plan.

4 Robot system

4.1 Sensors

Using infrared laser fan beam and camera with interference filter, the difference of height can be detected by triangulation with simple image processing. To satisfy the requirement of resolution, the laser source and the camera must be carefully configured. Fig.5 shows the configuration of this sensor system.

With a CCD camera which outputs NTSC video signal with a lens whose focal length is 8.5mm, the camera height should be 50cm high and laser irradiation angle must be

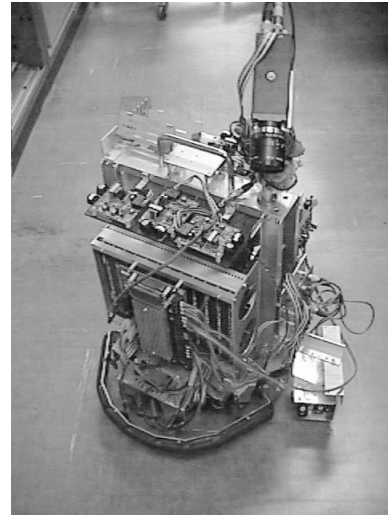

Figure 6: Mobile robot equipped with the laser source and the camera

less than 10 degrees to gain enough sensitivity to detect bumps of braille blocks that are 5mm high. Fig.6 shows the mobile robot with the sensor system, in the laser irradiation angle is 5 degree and the camera height is 55cm. Fig.7 shows an image taken with the camera. In this figure, laser fan beam can be found around the center of this image and the convex parts of the line style block are figured by the laser fan beam as the shape of it.

4.2 Mobile robot platform

The mobile robot which is used for this study is named YAMABICO-fra, one of YAMABICO family mobile robots developed in our laboratory[1]. Its dimensions are approximately 40 cm (W) × 40 cm (D) × 50 cm (H) without camera and 70 cm high including it.

4.3 Controllers

The controller architecture of YAMABICO-fra is shown in Fig.8. Function modules shown in bellow half are the common system of YAMABICO family mobile robot. Each function modules have own processor connected with transputer link or dual port memory and work simultaneously.

A note book PC running Linux is used as image processor and as main controller. The PC and the other function modules are connected with standard serial port to control low level function modules from the PC. Two of three TYPE-II PCMCIA slots are used by a Video capture card and an Ethernet card which is connected to a wireless LAN module for monitoring the robots status.

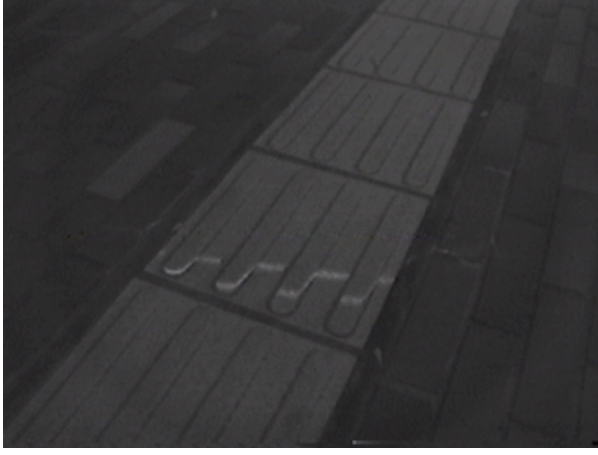

Figure 7: Image from the camera aimed at the line style block

5 Recognition of the line style block

The purpose of recognition of the line style block is to follow the sequence of line style blocks. Hence two parameters must be known. One is the distance between the line of the blocks and the robot and the other is angle between robot's heading direction and it of the line.

5.1 Position of the line style block

Because of line style block's shape, the block can be found by searching for periodically appearing bumps on the projected laser fan beam in a captured image (see Fig.9). Once the position of the bumps on the captured image determined, the actual position of the block on the ground can be calculated using following equations.

$$Y = h \tan(\theta + \phi)$$

$$X = \frac{h \Delta x (x_c - x)}{f \cos(\theta + \phi)}$$

$$\phi = \arctan\left(\frac{\Delta y (y_c - y)}{f}\right)$$

- f : Focal length of the camera
- h : Height of the camera position
- $\Delta x, \Delta y$: CCD pixel size
- θ : Camera angle of depression
- x_c, y_c : Position of optical center
- X, Y : Actual position relative to the camera

This function uses the camera position relative to road surface. If the robot becomes unstable and swing his head

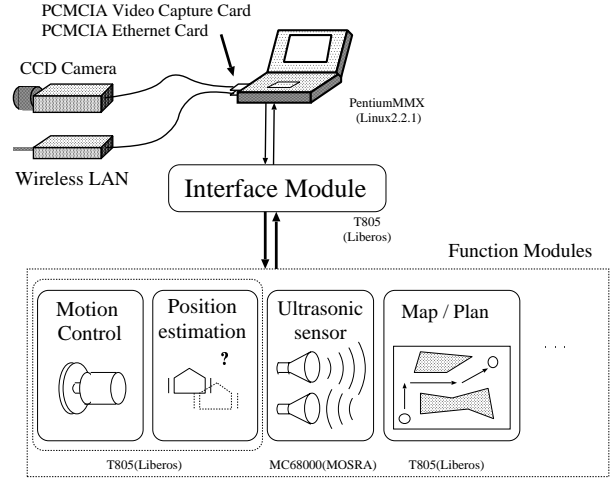

Figure 8: The controller architecture of YAMABICO-frac

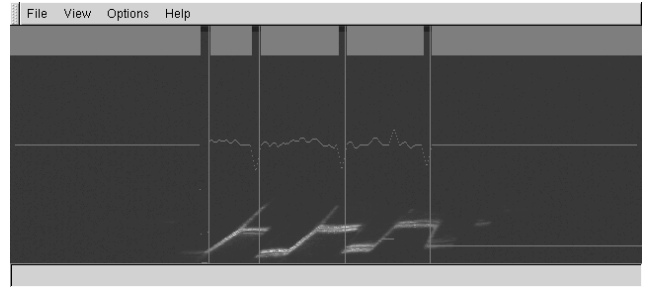

Figure 9: The captured image and drawn result of bump searched on it as vertical line

back and forth, these parameter may change.

Assuming the laser irradiation angle is small enough and relative position of laser source from the camera is fixed, coordinates on the road surface and on the surface of laser fan beam are almost the same. Hence the previous equations can be altered by the followings (see Fig.10).

$$Y = l - \frac{l}{\cos \theta_c \left(1 + \frac{l \tan \theta_c}{d}\right)}$$

$$X = \frac{Y \cos \phi \Delta x (x_c - x)}{\cos \left(\theta_c + \arctan\left(\frac{\Delta y (y_c - y)}{f}\right)\right) \sqrt{f^2 + (\Delta y (y_c - y))^2}}$$

$$d = \frac{l \Delta y (y_c - y)}{f}$$

- l : Distance between the camera and the crossing point of the optical axis and surface of laser fan beam

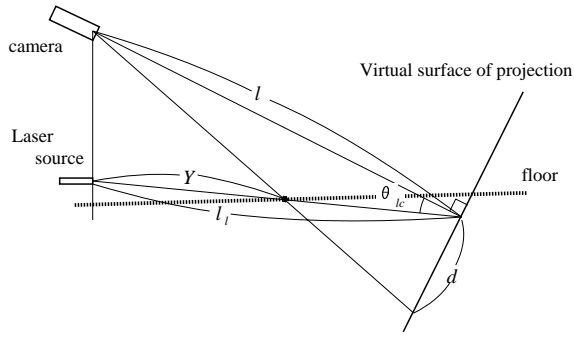

Figure 10: A model for coordinate transformation without parameters relative to road surface

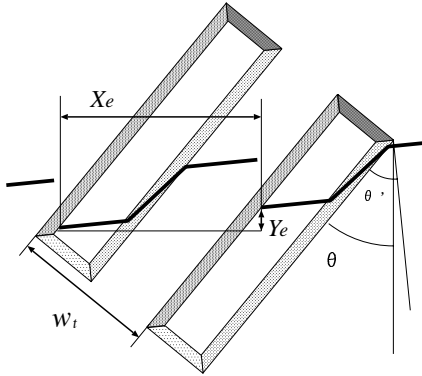

Figure 11: The line style block on which laser fan beam projected

- l_l : Distance between the laser source and the crossing point of the optical axis of the camera and surface of laser fan beam
- θ_{lc} : Angle between optical axis of the camera and surface of laser fan beam

5.2 Direction of the line of blocks

Comparing the detected interval of bumps and the actual distance of convex parts on the line style block, the direction of the line of blocks can be calculated as follows (see Fig.5.2).

$$\theta = \arccos\left(\frac{\sqrt{X_e^2 + Y_e^2}}{W_t}\right) - \arctan\left(\frac{Y_e}{X_e}\right)$$

- θ : relative angle of the line style block points to from the robot



Figure 12: Experimental environment

W_t : actual interval of convex parts on the block

X_e, Y_e : detected interval of bumps

6 Experimental results

With the mobile robot YAMABICO-fra, an experiment of line style block following and dot style block detection has been conducted to confirm the proposed recognition method.

In this experiment, the robot does not have the environmental map and just follows line style blocks. Fig.12 shows experimental environment. The path defined by line style blocks includes a corner without dot style block. The experiment has been done just after sunset and also day time of cloudy day.

The robot runs at $9cm/s$ and captures camera image every $200ms$, and it is frequent enough to get sufficient number of clean images that the laser beam is not crossing the connected points of line style blocks.

Fig.13 shows the result of this experiment. The initial position of the robot is at $(0,0)$ and heading to positive direction of x axis. The robot successfully follow the line style blocks in this experiment. At the corner, it failed tracking line style block in short term because of narrow sensor range. But the robot detects not only the position of the line style blocks but also their direction, it could follow new direction and start tracking new line of blocks again.

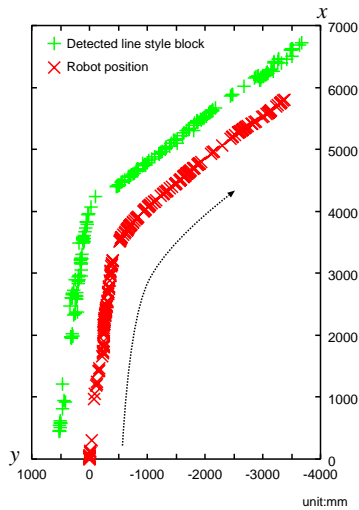

Figure 13: Detected line style block positions and detected position of the robot

7 Conclusion

In this paper, we described a detection method of braille blocks for mobile robot navigation and presented sensor system for recognition of braille blocks. Using this sensor system, mobile robot can follow the line style blocks and detect the dot style blocks. The result of the experiment shows effectiveness of this method in both indoor and outdoor environments.

In the future work, we will implement a dot style block detection algorithm which is not described in this paper. Also we will construct the navigation system for out door environment using proposed sensor system.

References

- [1] S. Yuta, "Autonomous Self-contained Robot 'Yamabico' and its Controller Architecture", *Third Australia National Conference on Robotics*, June 1990
- [2] S. Kotani, K. Kaneko, T. Shinoda, H. Mori, "Mobile robot Navigation Based on Vision and DGPS Information", *International Conference on Robotics and Automation*, pp.2524-2529, May 1998
- [3] C.Thorpe, M.H.Hebert, K.Kanade, S.A.Shafer, "Vision and Navigation for the Carnegie-Mellon Navlab", *IEEE Transactions on Pattern Analysis and Machine Intelligence*, Vol.10,No.3,pp.362-373, May 1988
- [4] S. Yuta, S. Suzuki, Y. Saito, S. Iida, "Implementation of an Active Optical Range Sensor Using Laser Slit for In-Door Intelligent Mobile Robot", *International Conference of Intelligent Robots and Systems*, November 1991
- [5] S. Tachi, K.Komoriya "Guide Dog Robot" *International Symposium on Robotics Research* Vol.2, pp.333-340
- [6] H. Mori, K. Kobayashi, N. Ohtuki, S. Kotani, "Color Impression Factor: an Image Understanding Method for Outdoor Mobile Robots", *International Conference of Intelligent Robots and Systems*, pp.380-387, September 1997